CAN GREENER SOLVENTS MAKE COLLAGEN EXTRACTION MORE SUSTAINABLE? WHAT DOES LCA TELL US



UPCOMING WEBINAR:

From Source to Standard: What Quality Actually Means in Collagen

APRIL 28TH | 9AM CST

Dr. Miguel Batista

PhD in Chemical and Biological Engineering

www.linkedin.com/in/miguel-batista-researcher





Dr. Miguel Batista



R&D Associate
Canna.Biz (Torres Vedras, Portugal)



PhD in Chemical and Biological Engineering
iBET (Oeiras, Portugal)
NOVA School of Science and Technology (Caparica, Portugal)

Framework

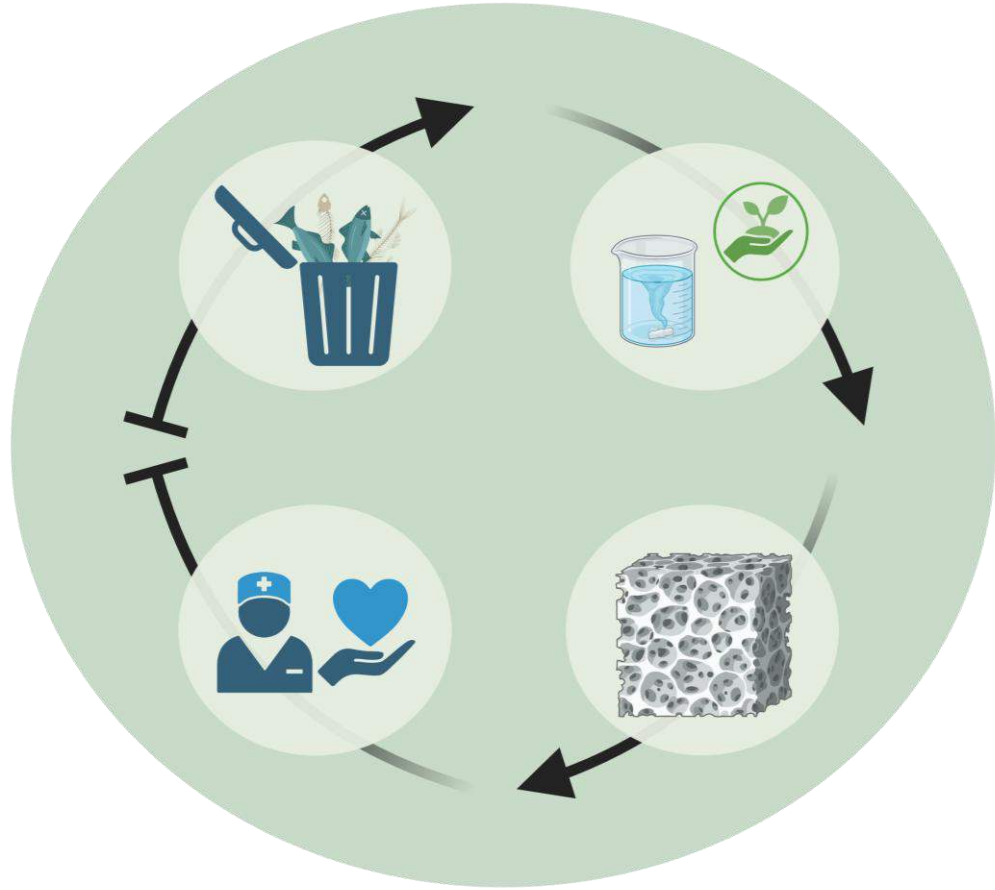

Framework

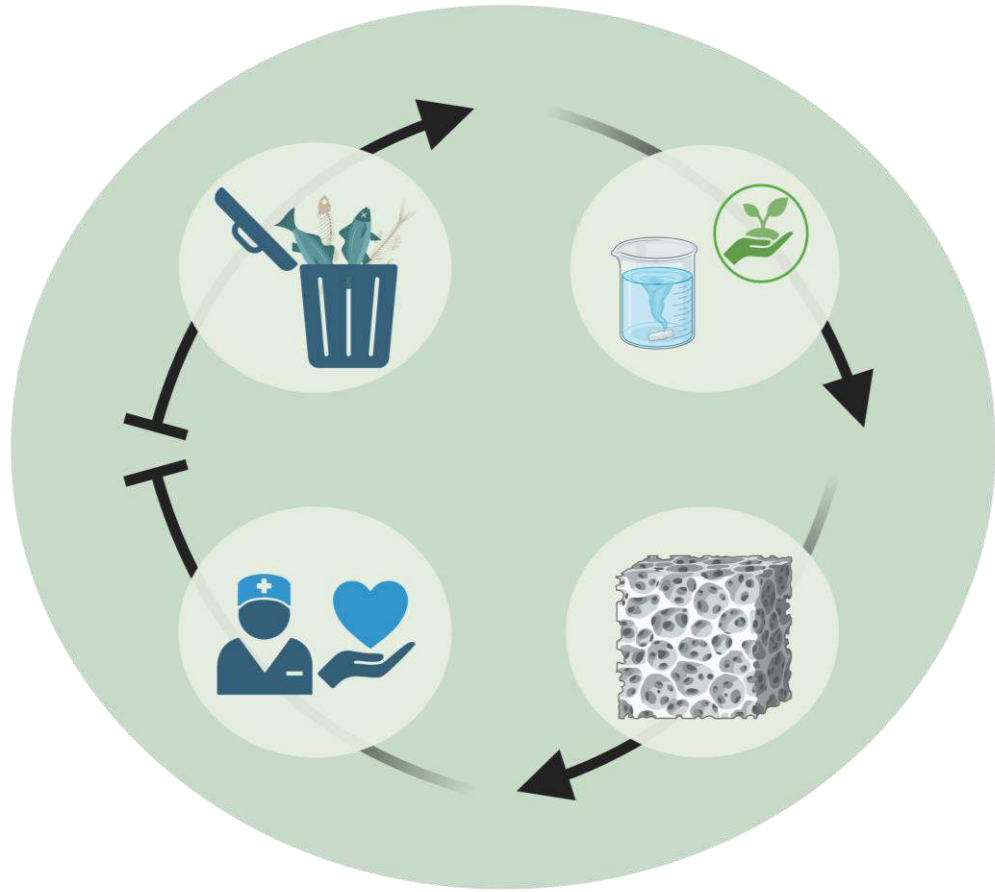

1 | Introduction

Framework

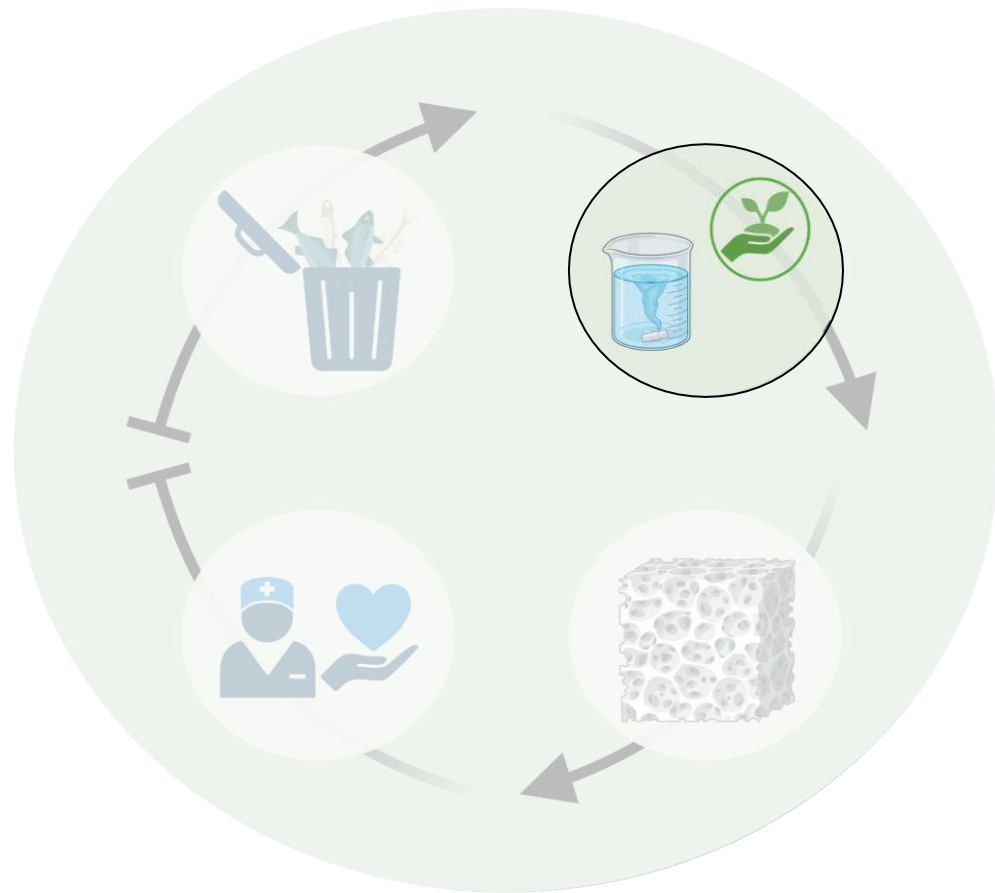

2 | Marine collagen extraction

ORIGINAL RESEARCH article

Front. Chem., 16 June 2022
Sec. Green and Sustainable Chemistry
Volume 10 - 2022 |
<https://doi.org/10.3389/fchem.2022.937036>

Extraction of Biocompatible Collagen From Blue Shark Skins Through the Conventional Extraction Process Intensification Using Natural Deep Eutectic Solvents

Miguel P. Batista^{1,2} Naiara Fernández¹ Frédéric B. Gaspar^{1,3}
 Maria do Rosário Bronze^{1,3,4} Ana Rita C. Duarte^{2*}

¹ iBET, Instituto de Biologia Experimental e Tecnológica, Oeiras, Portugal

² LAQV-REQUIMTE, Departamento de Química, Faculdade de Ciências e Tecnologia, Universidade Nova de Lisboa, Caparica, Portugal

³ Instituto de Tecnologia Química e Biológica António Xavier, Universidade Nova de Lisboa, Oeiras, Portugal

⁴ FFULisboa, Faculty of Pharmacy, University of Lisbon, Lisbon, Portugal



iBET

NOVA
FACULDADE DE
CIÊNCIAS E TECNOLOGIA

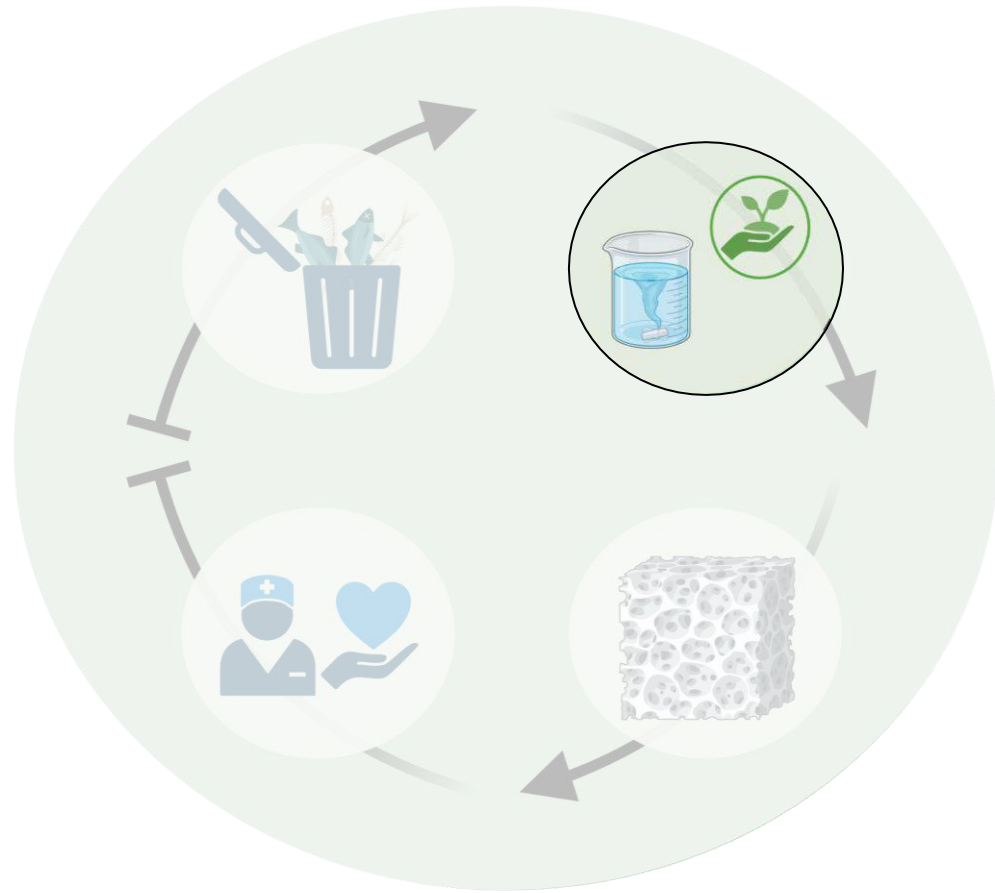

3 | Life cycle assessment





Journal of Environmental Chemical
Engineering

Volume 13, Issue 2, April 2025, 115911



Sustainability assessment of collagen extraction from fish skins: A comparative life cycle assessment of conventional and NADES-enhanced processes

Miguel P. Batista ^{a b}, Joana Ortigueira ^c, Naiara Fernández ^a, Frédéric B. Gaspar ^{a d},
Maria do Rosário Bronze ^{a d e}, Ana Rita C. Duarte ^b, Tiago F. Lopes ^c  



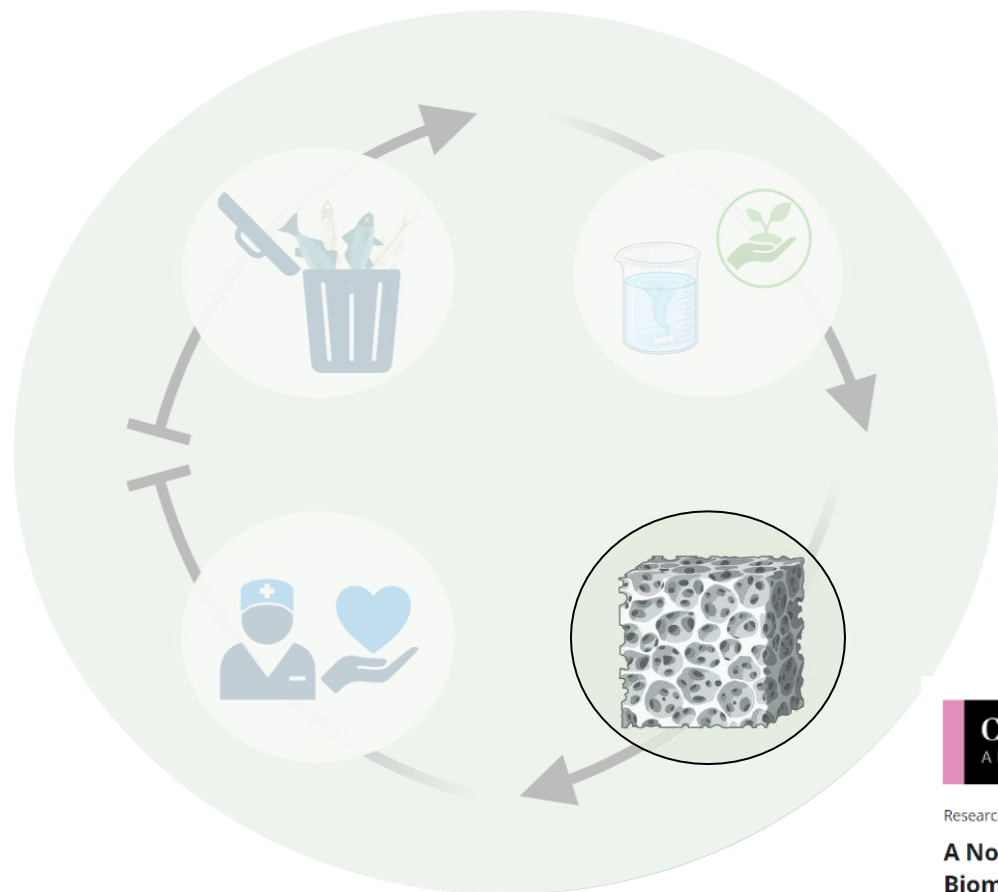

Collagen biomaterials



Research Article | [Open Access](#)

A Novel Collagen Aerogel with Relevant Features for Topical Biomedical Applications

Miguel P. Batista, Dr. Baldur Schroeter, Dr. Naiara Fernández, Dr. Frédéric Bustos Gaspar, Prof. Dr. Maria do Rosário Bronze, Prof. Dr. Ana Rita Duarte, Dr. Pavel Gurikov

First published: 05 April 2024 | <https://doi.org/10.1002/cplu.202400122> | Citations: 1

[Open Access](#) [Article](#)

Collagen–Chitosan Composites Enhanced with Hydroxytyrosol for Prospective Wound Healing Uses

by Miguel P. Batista ^{1,2} , Margarida Pimenta ^{1,3} , Naiara Fernández ¹ , Ana Rita C. Duarte ² , Maria do Rosário Bronze ^{1,3,4} , Joana Marto ^{5,*} and Frédéric Bustos Gaspar ^{1,3,*}

- ¹ IBET—Instituto de Biologia Experimental e Tecnológica, Apartado 12, 2781-901 Oeiras, Portugal
 - ² LAQV-REQUIMTE, Associated Laboratory for Green Chemistry—Network of Chemical and Technology, Departamento de Química, Faculdade de Ciências e Tecnologia, Universidade Nova de Lisboa, Quinta da Torre, 2829-516 Caparica, Portugal
 - ³ Instituto de Tecnologia Química e Biológica António Xavier, Universidade Nova de Lisboa, Av. da República, 2780-157 Oeiras, Portugal
 - ⁴ FFULisboa, Faculty of Pharmacy, Universidade de Lisboa, Av. das Forças Armadas, 1649-019 Lisboa, Portugal
 - ⁵ Research Institute for Medicines (iMed.ULisboa), Faculty of Pharmacy, Universidade de Lisboa, Av. das Forças Armadas, 1649-003 Lisboa, Portugal
- * Authors to whom correspondence should be addressed.

Pharmaceutics **2025**, *17*(5), 618; <https://doi.org/10.3390/pharmaceutics17050618>

Submission received: 16 March 2025 / Revised: 18 April 2025 / Accepted: 28 April 2025 / Published: 6 May 2025

(This article belongs to the Special Issue Drug Delivery of Natural Active Principles: Focus on Topical and Oral Applications, 2nd Edition)



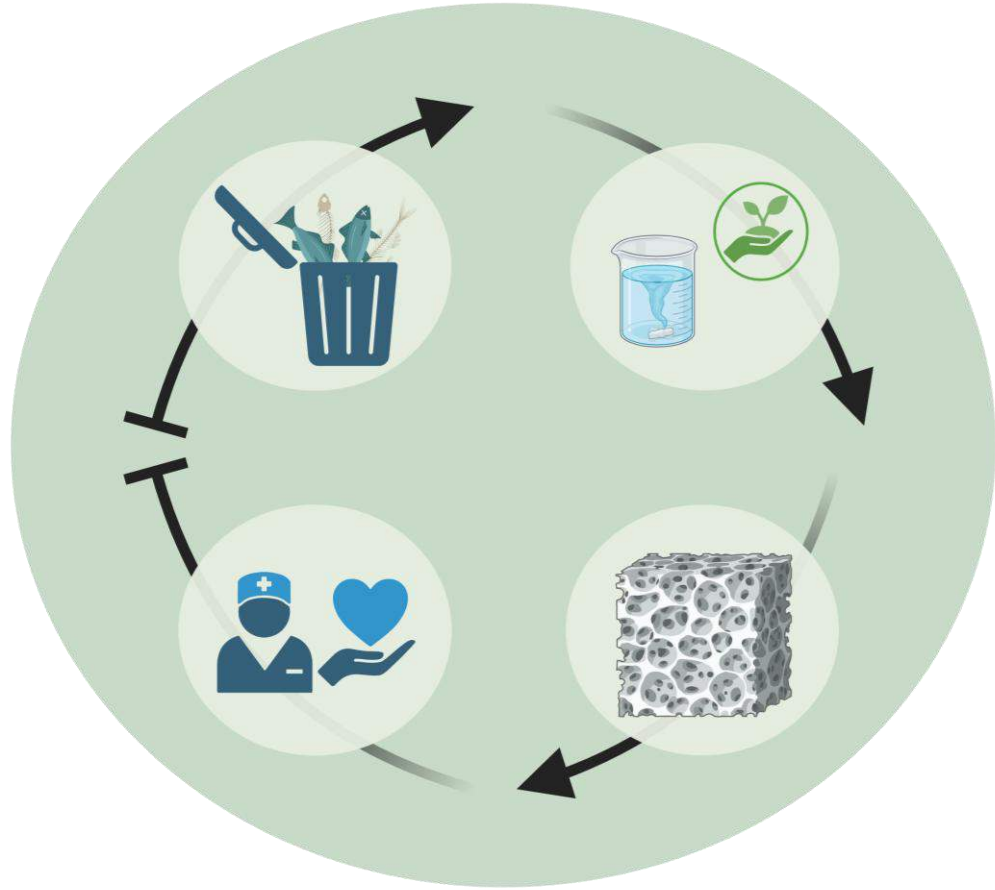

1 | Introduction

1 | Introduction

Food waste in the EU by main economic sectors, 2021

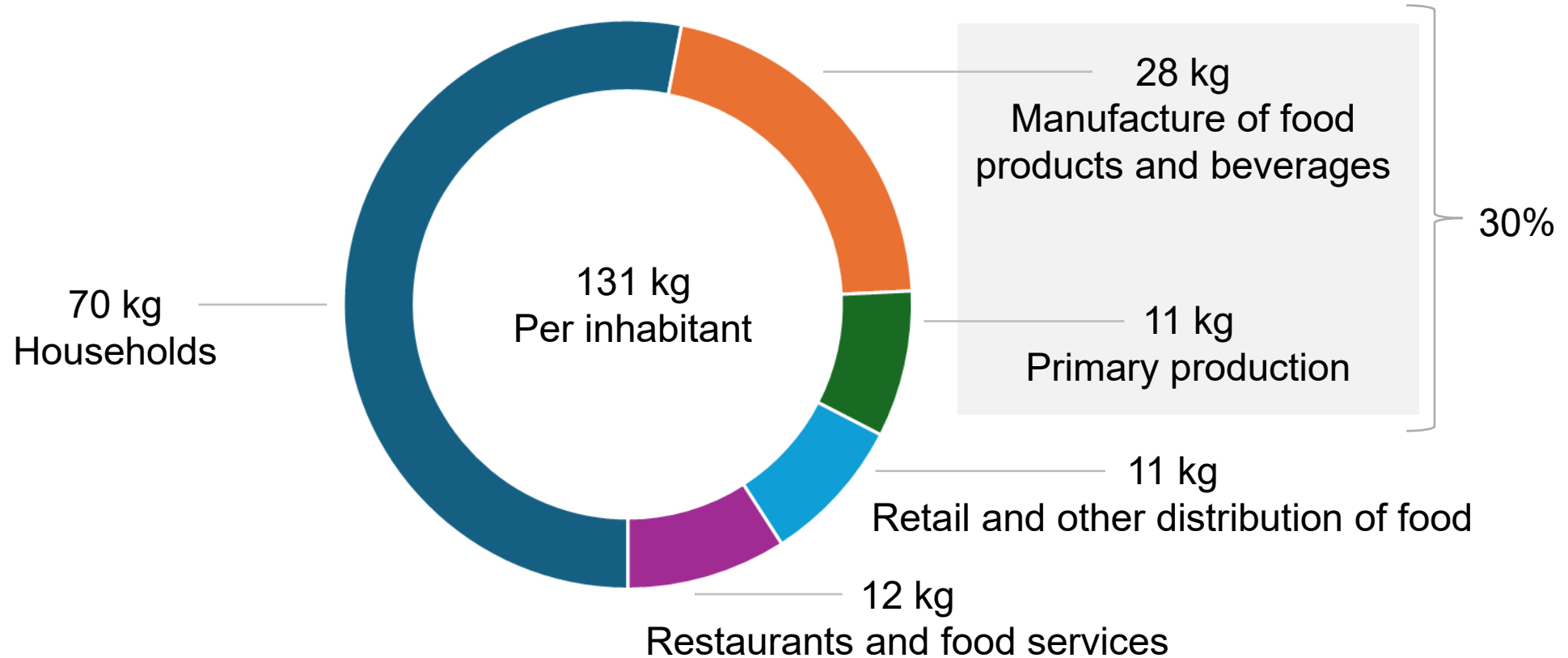

1 | Introduction

Waste and byproducts in the fisheries and aquaculture sectors

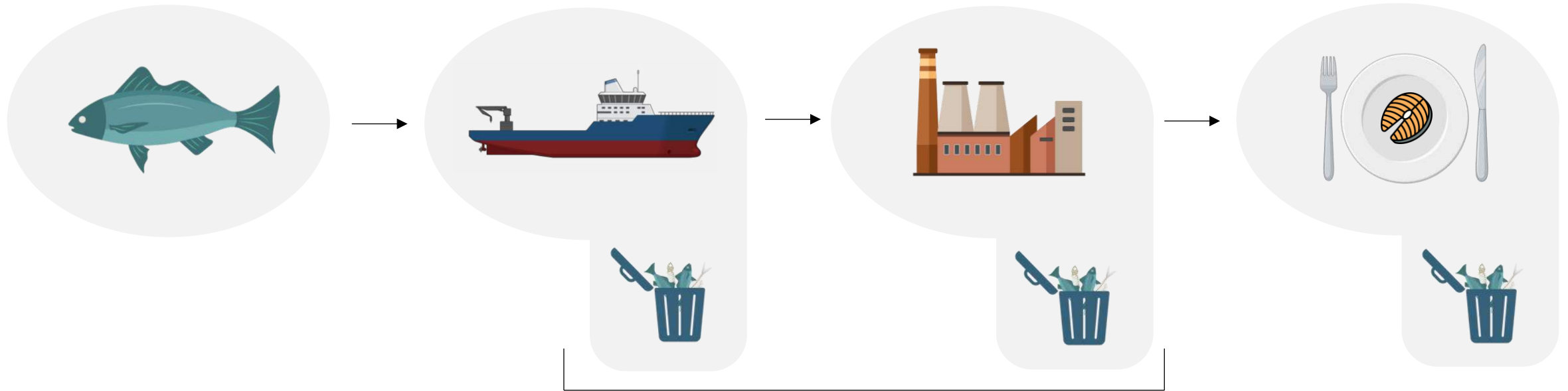

25-75% of fish weight is discarded



- Top EU country per capita consumer of fishery and aquaculture products
- Top 20 world per capita aquatic food consumers
- Top 30 world exporters of aquatic animals

1 | Introduction

Waste and byproducts in the fisheries and aquaculture sectors

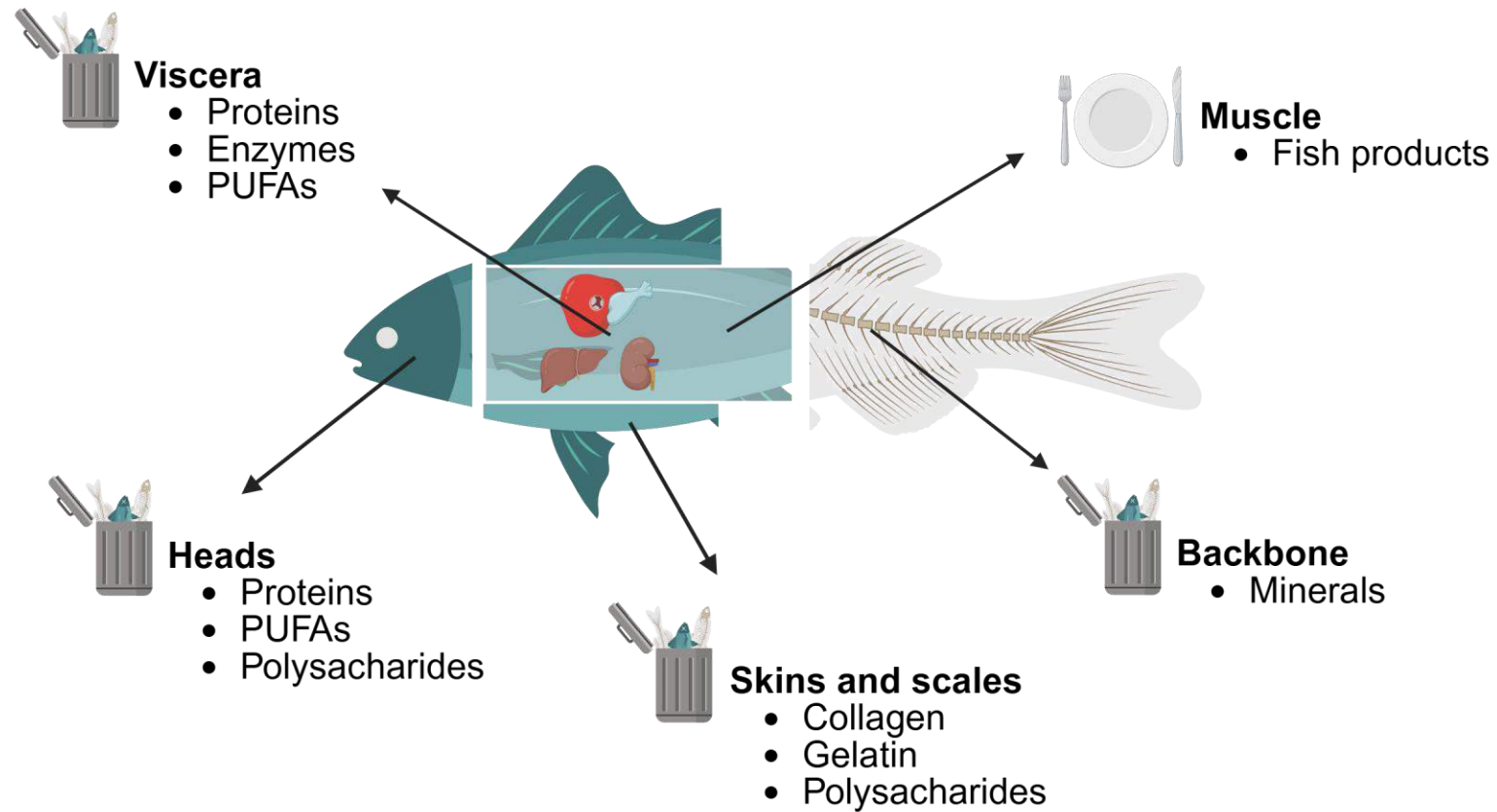

1 | Introduction

Marine collagen

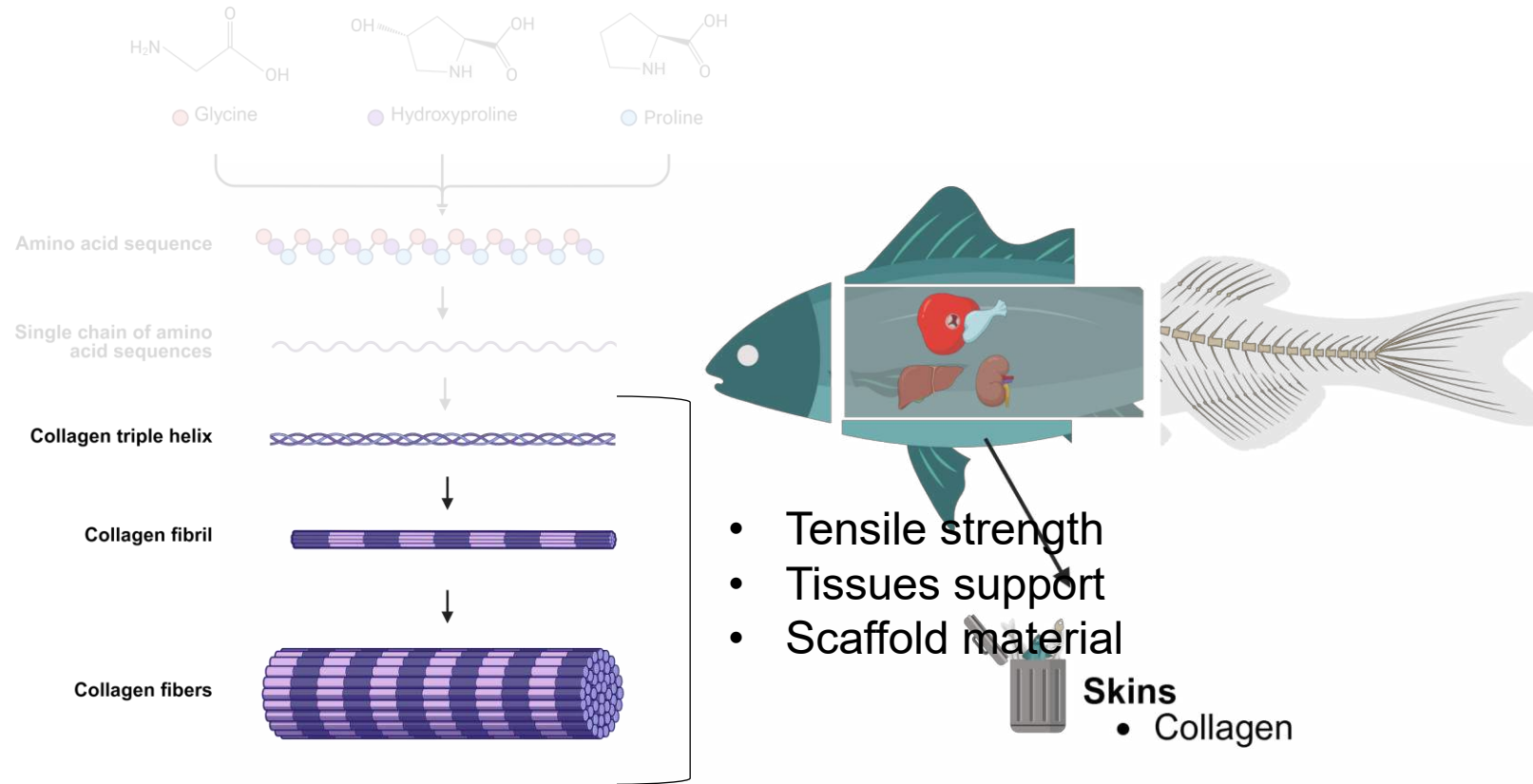

Biomedical
Cosmetic
Food

1 | Introduction

Marine collagen global market

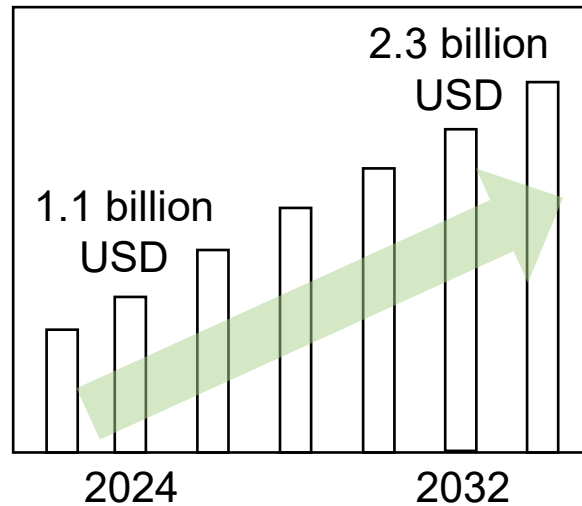

- Abundant source availability
- Low risk of infection-causing agents' transmissions
- Less associated with cultural and religious concerns

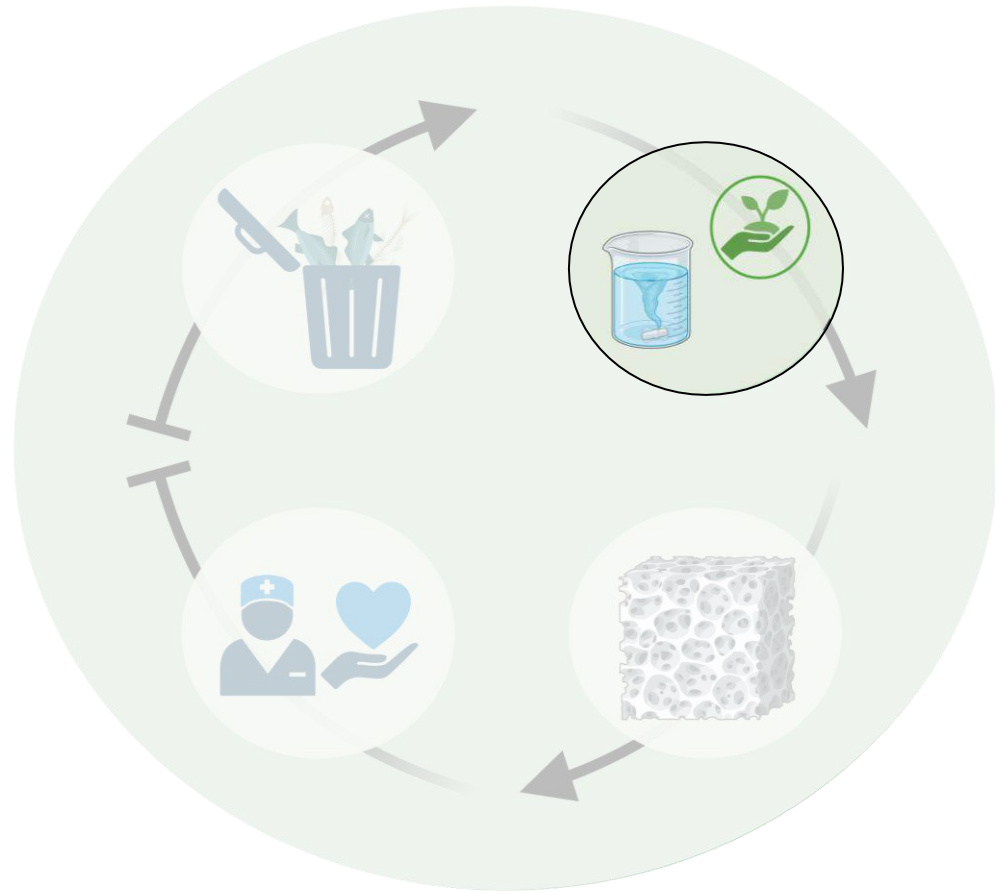





2 | Marine collagen extraction

ORIGINAL RESEARCH article

Front. Chem., 16 June 2022
Sec. Green and Sustainable Chemistry
Volume 10 - 2022 |
<https://doi.org/10.3389/fchem.2022.937036>

Extraction of Biocompatible Collagen From Blue Shark Skins Through the Conventional Extraction Process Intensification Using Natural Deep Eutectic Solvents

 Miguel P. Batista^{1,2}  Naiara Fernández¹  Frédéric B. Gaspar^{1,3}
 Maria do Rosário Bronze^{1,3,4}  Ana Rita C. Duarte^{2*}

¹ iBET, Instituto de Biologia Experimental e Tecnológica, Oeiras, Portugal

² LAQV-REQUIMTE, Departamento de Química, Faculdade de Ciências e Tecnologia, Universidade Nova de Lisboa, Caparica, Portugal

³ Instituto de Tecnologia Química e Biológica António Xavier, Universidade Nova de Lisboa, Oeiras, Portugal

⁴ FFULisboa, Faculty of Pharmacy, University of Lisbon, Lisbon, Portugal

2 | Marine collagen extraction

Prionace glauca | Blue shark | Tintureira

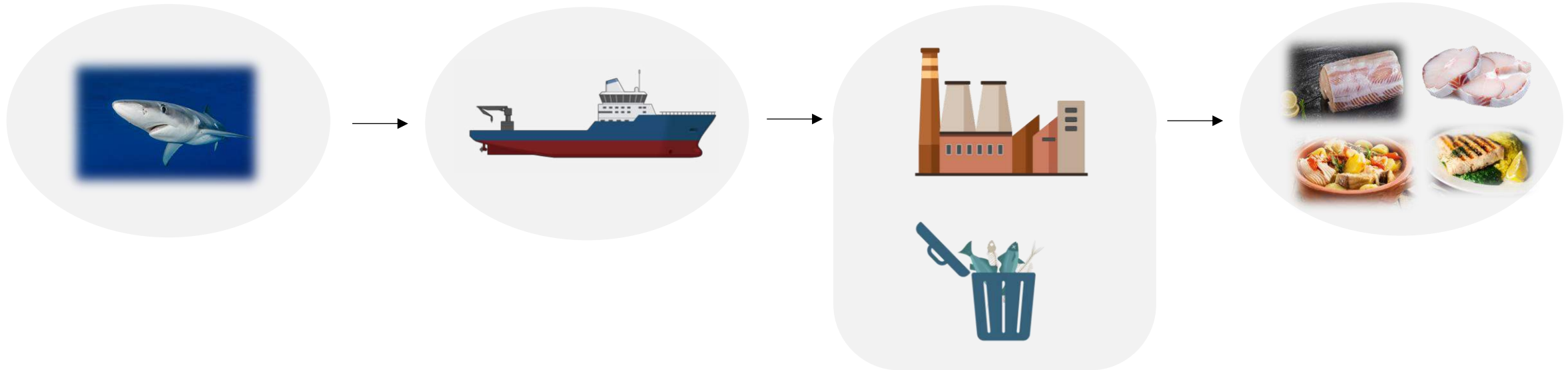

“Our company produces about 400 kg/day of fish skins resulting from blue shark processing”

Vitorino & Filhos Lda (Peniche)

2 | Marine collagen extraction

Conventional approach



- Blue shark skins waste

- Collagen



- Several pre-treatment steps
- Long extraction times
- Low temperatures
- Chemical-intensive treatments
- Extensive water use

High ecological footprint

Few greener alternatives available

2 | Marine collagen extraction

Conventional approach

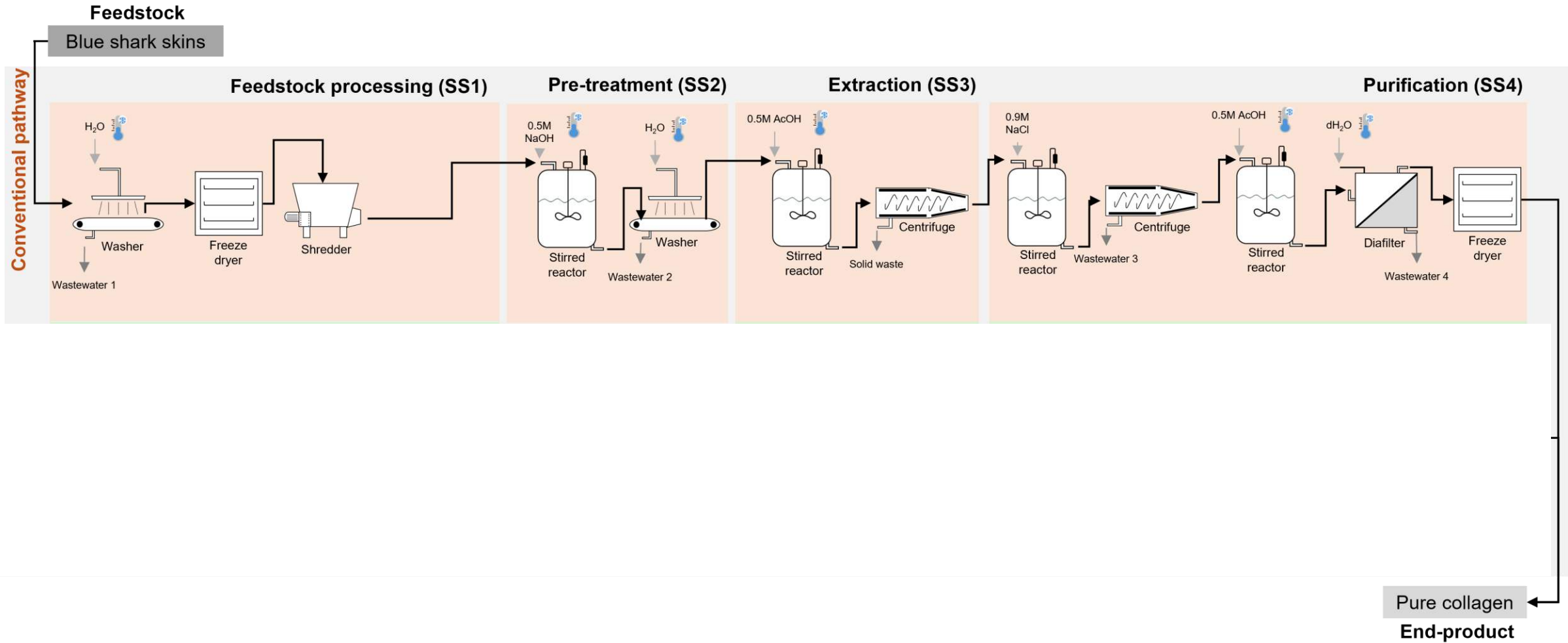

2 | Marine collagen extraction

Conventional approach

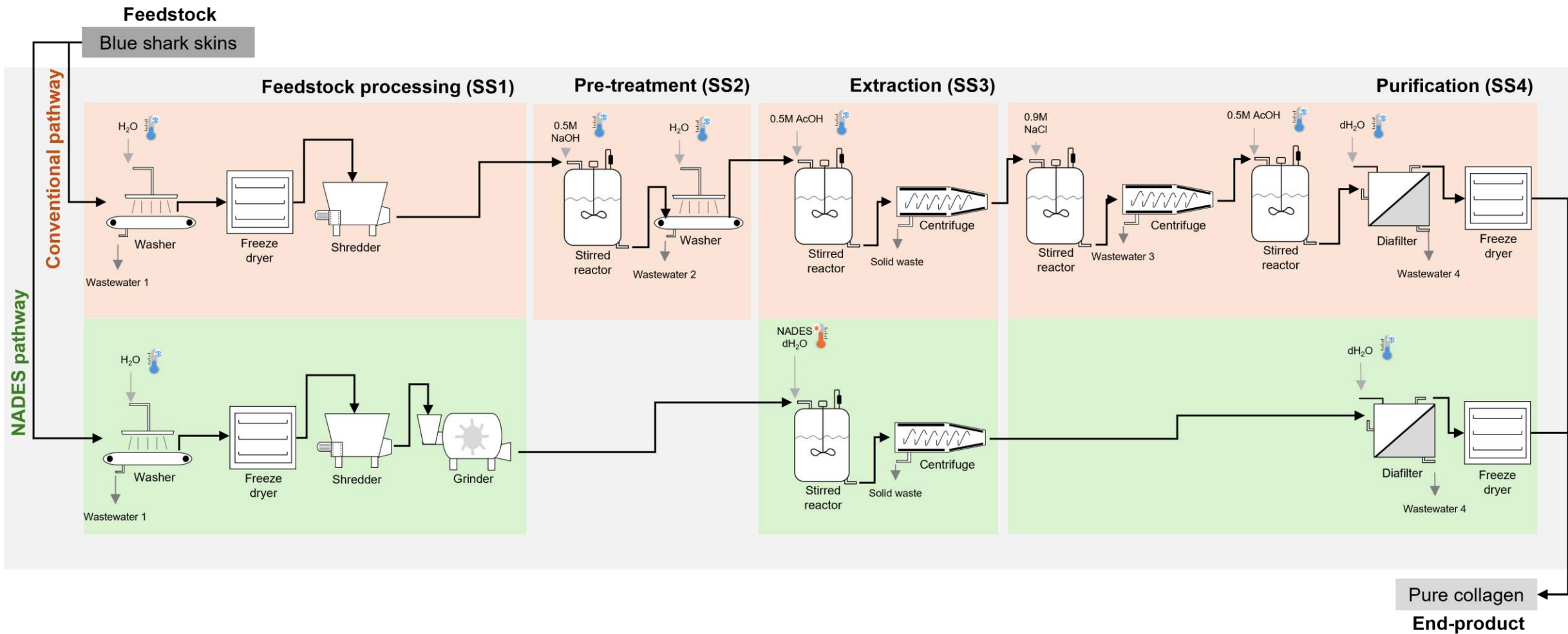

iBET

Nova
FACULDADE DE
CIÊNCIAS E TECNOLOGIA

2 | Marine collagen extraction

NADES approach

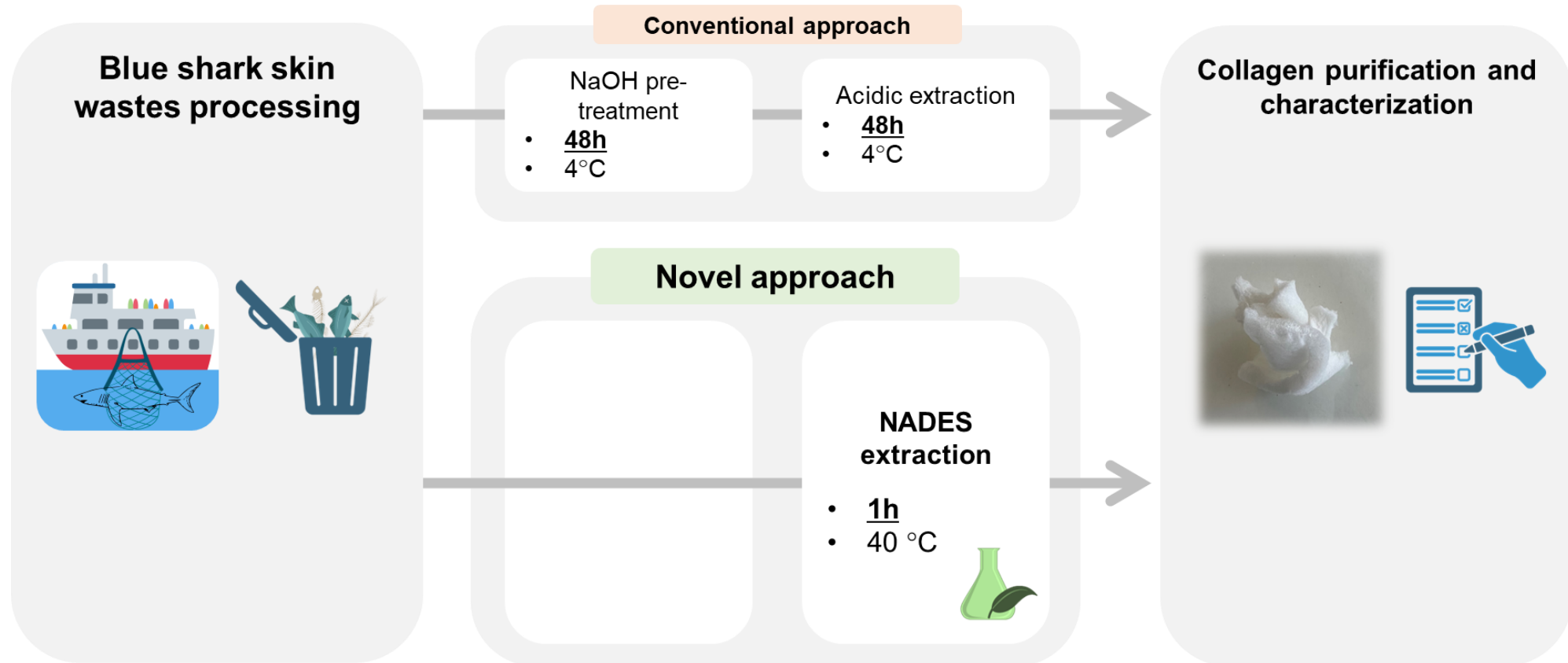

2 | Marine collagen extraction

NADES approach

Natural Deep Eutetic Solvent (NADES)

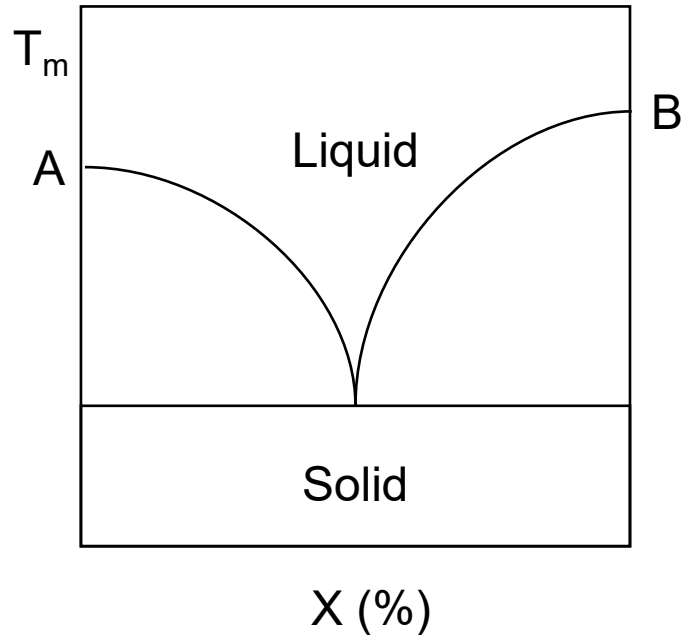

- Non-toxic
- Biodegradable
- Biocompatible
- High and tunable viscosity



iBET

NOVA
FACULDADE DE
CIÊNCIAS E TECNOLOGIA

2 | Marine collagen extraction

NADES approach

NADES

Citric Acid : Xylitol : Water (1:1:10)

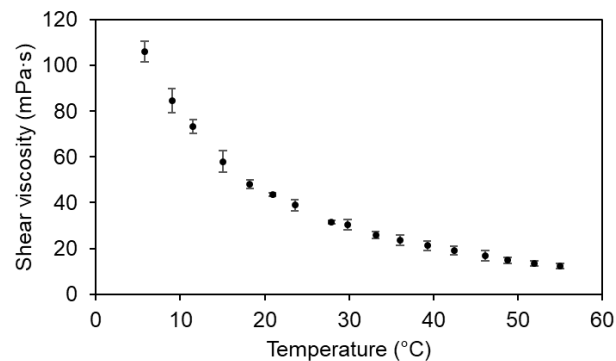

[3] Grønlien KG, Pedersen ME, Tønnesen HH. A natural deep eutectic solvent (NADES) as potential excipient in collagen-based products. *Int J Biol Macromol* 2020;156:394–402. <https://doi.org/10.1016/j.ijbiomac.2020.04.026>.

Extraction yield (%) of the extracts obtained from **conventional** and **NADES** methodologies

Methodology	Operating conditions		Extraction yield (%)
	NaOH Pre-treatment	Collagen extraction	
Conventional	48 h; 4 °C	48 h; 4 °C	7.57 (±3.53)
NADES	-	1 h; 40 °C	18.6 (±3.82)

↓ Fewer processing steps

↓ Shorter extraction time

↑ Higher extraction yield

2 | Marine collagen extraction

Characterization: NADES | Conventional | Commercial reference

Gel Electrophoresis (SDS-PAGE)

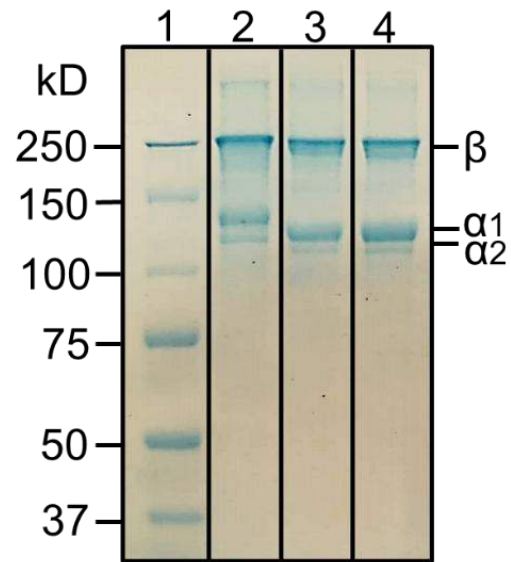

- (1) molecular weight standards
- (2) commercial collagen type I from calf skin
- (3) collagen extracted using conventional method
- (4) collagen from NADES extraction

Circular dichroism

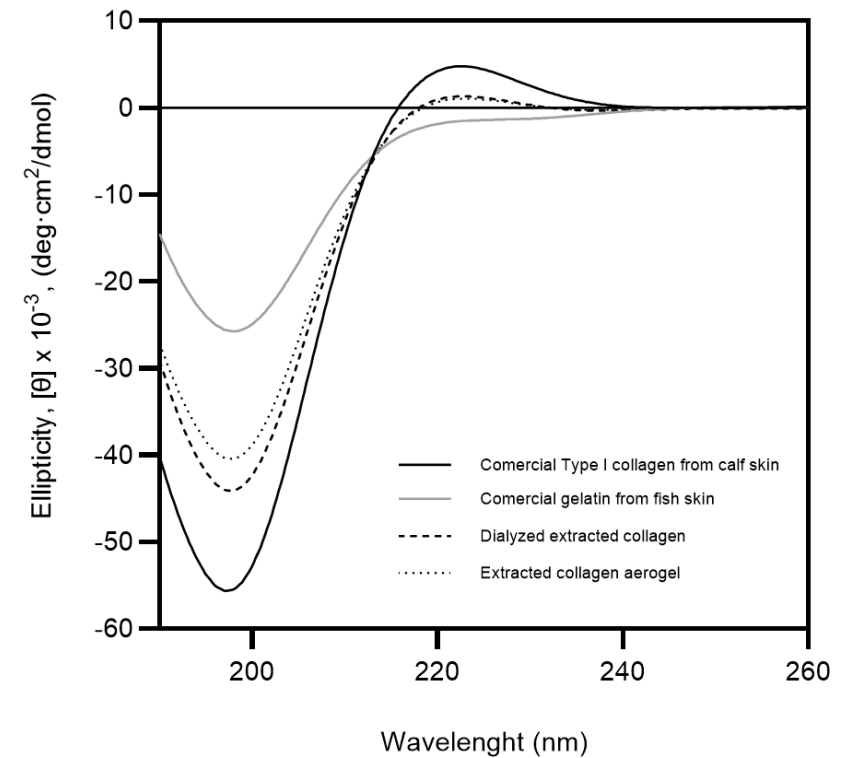

2 | Marine collagen extraction

Characterization: NADES | Conventional | Commercial reference

Fourier Transform Infrared (FTIR) spectroscopy

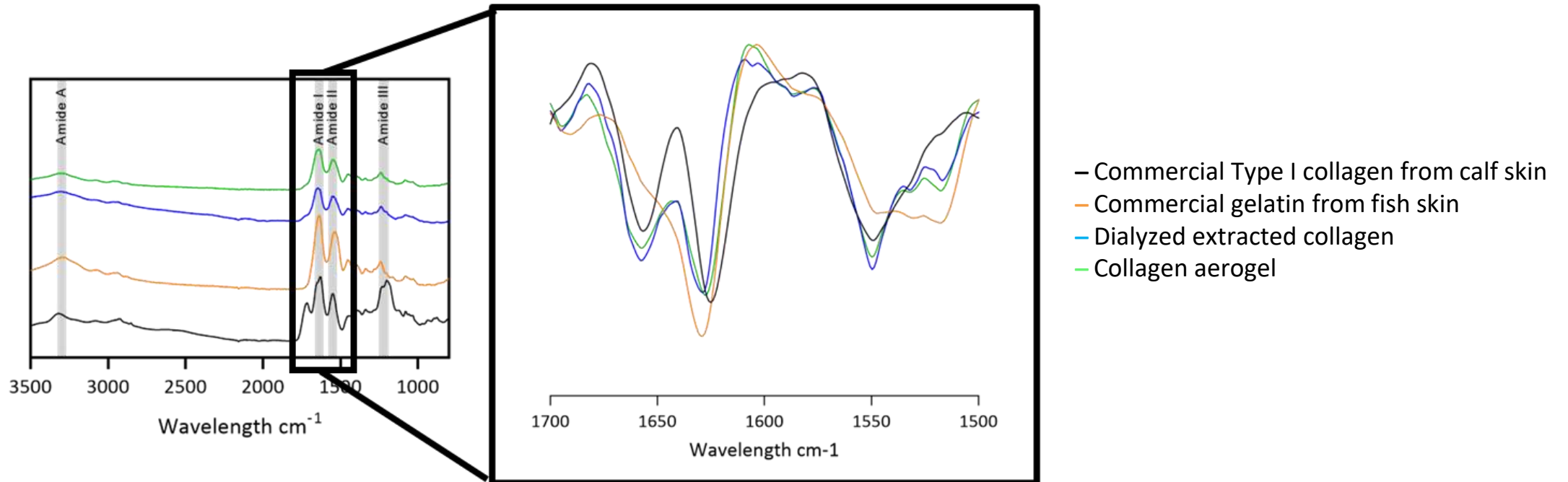

2 | Marine collagen extraction

Characterization: NADES | Conventional | Commercial reference

Hg quantification

Sample	Hg content (mg/kg dry weight)
Shark skins	1.64 (± 0.48)
Collagen extract	< Detection limit (0.01 mg/kg)

Cytocompatibility

Mouse fibroblasts NCTC clone 929

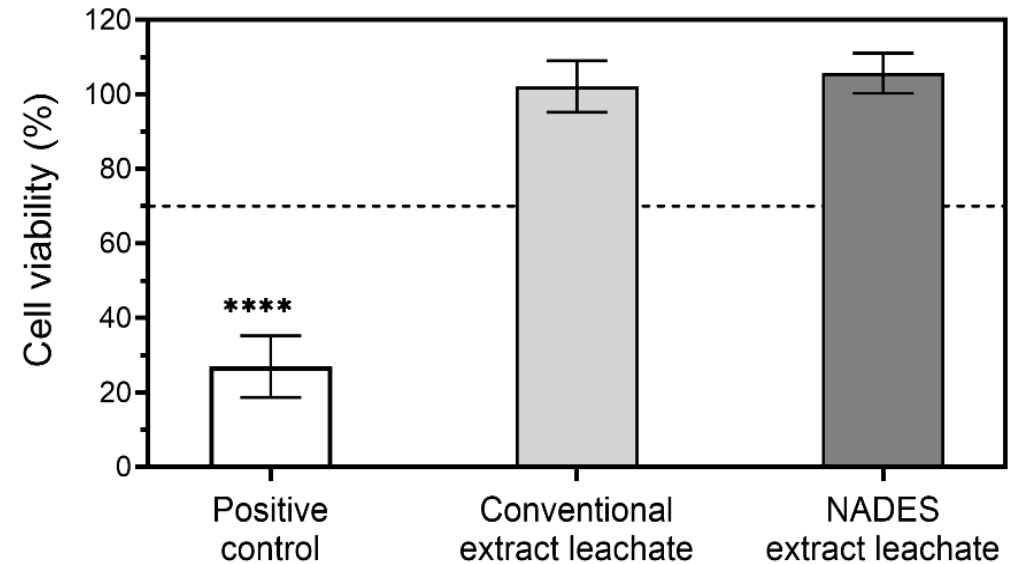

2 | Marine collagen extraction

Final remarks

?

- ✓ Pure collagen was successfully extracted using a **greener,** faster, and more straightforward extraction methodology with a similar structure and a superior yield than the conventional extraction method.

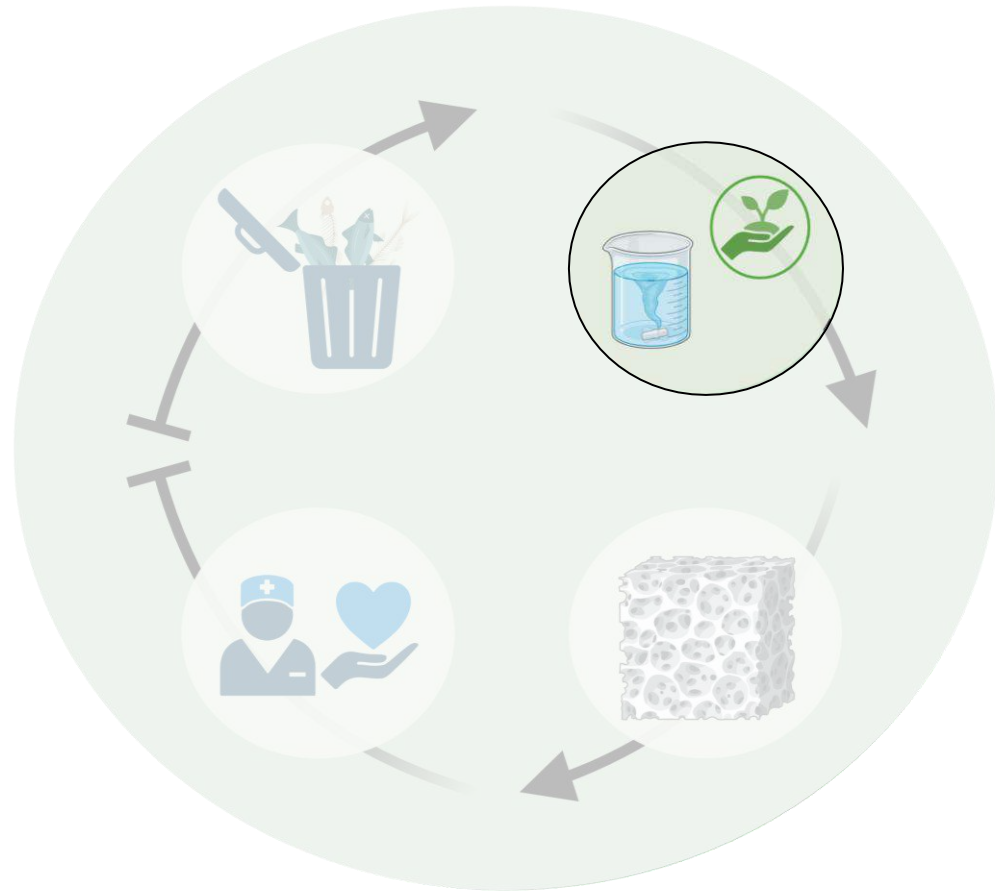

3 | Life cycle assessment



Journal of Environmental Chemical
Engineering

Volume 13, Issue 2, April 2025, 115911



Sustainability assessment of collagen extraction from fish skins: A comparative life cycle assessment of conventional and NADES-enhanced processes

Miguel P. Batista ^{a b}, Joana Ortigueira ^c, Naiara Fernández ^a, Frédéric B. Gaspar ^{a d},
Maria do Rosário Bronze ^{a d e}, Ana Rita C. Duarte ^b, Tiago F. Lopes ^c



Laboratório Nacional de Energia e Geologia, I. P.

3 | Life cycle assessment

Process simulation | Mass and energy balances | SuperPro Designer v8.5.2

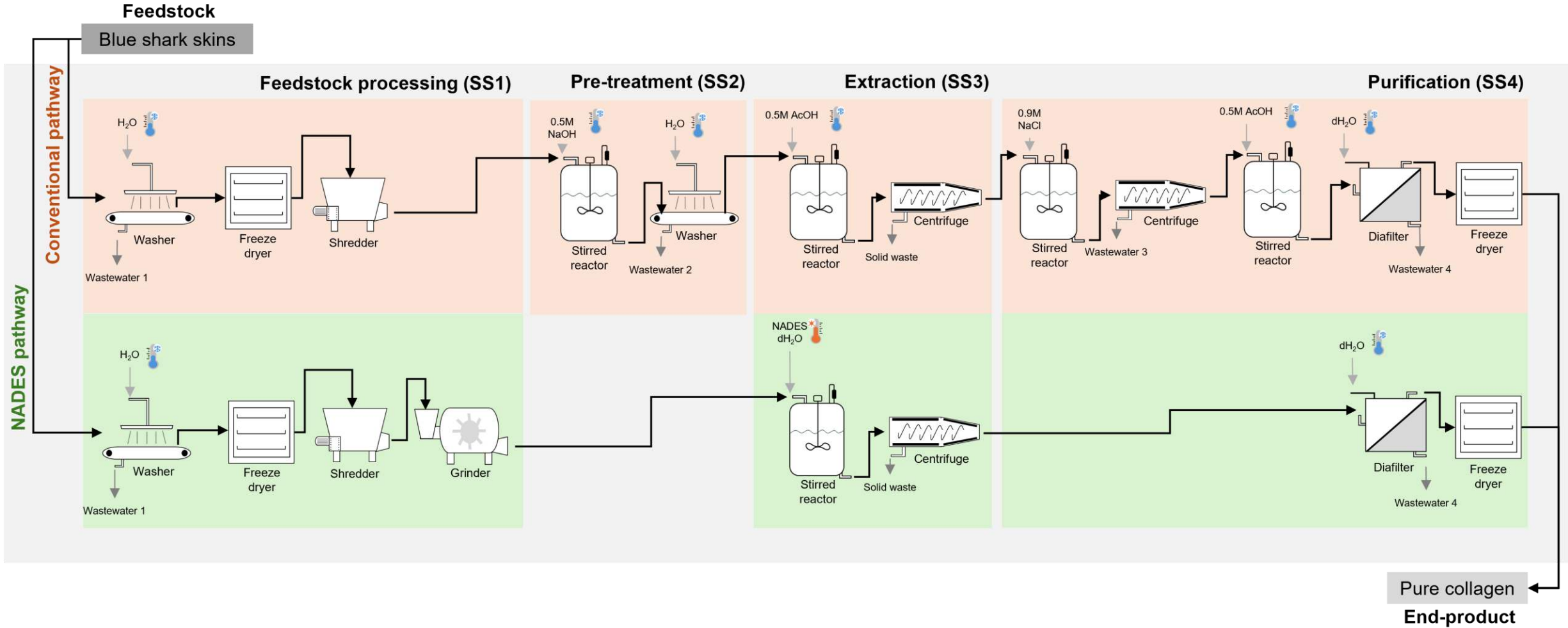

3 | Life cycle assessment

Process simulation | Mass and energy balances | SuperPro Designer v8.5.2

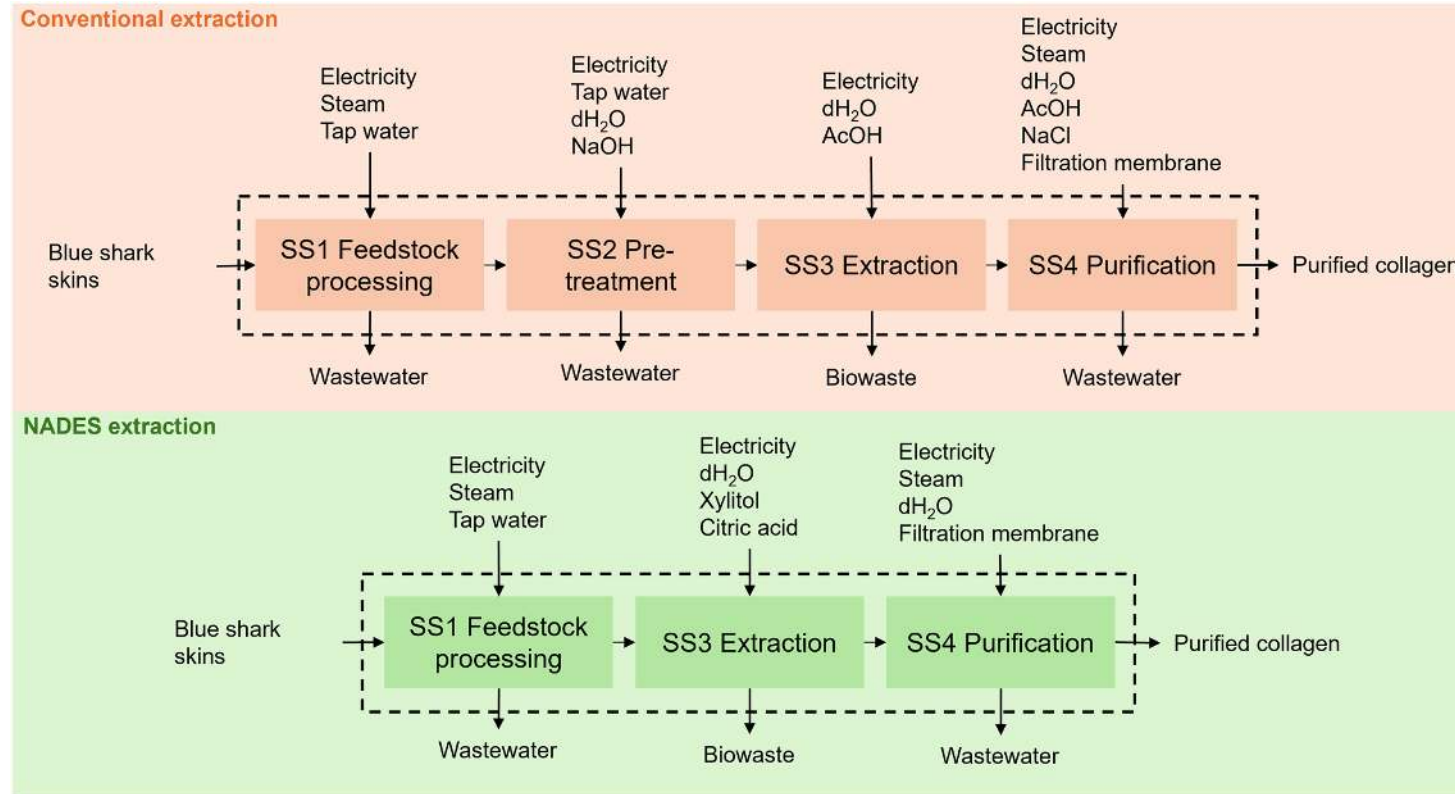

3 | Life cycle assessment

Impact analysis

	Inputs (t/year)	Outputs (t/year)	Utilities and Consumables
Conventional extraction	Feedstock	22	Pure collagen 0.5 (MWh/year)
	Tap water	2940	Solid waste 92 Electricity 196
	dH ₂ O	13254	Wastewater 15558 Heat demand 93
	NaOH	14	Cooling demand 426
	AcOH	47	(m ² /year)
	NaCl	52	Filtration membrane 1724
NADES extraction	Feedstock	9	Pure collagen 0.5 (MWh/year)
	Tap water	937	Solid waste 17 Electricity 23
	dH ₂ O	837	Wastewater 1726 Heat demand 62
	Citric acid	10	Cooling demand 45
	Xylitol	8	(m ² /year)
			Filtration membrane 23



SimaPro software (v8.5.2)
 Ecoinvent database (v3.4)
 Environmental Footprint (EF) 3.0 method



3 | Life cycle assessment

Impact analysis – Conventional approach

Subsystems:

SS1-Feedstock processing

SS2-Pretreatment

SS3-Extraction

SS4-Purification

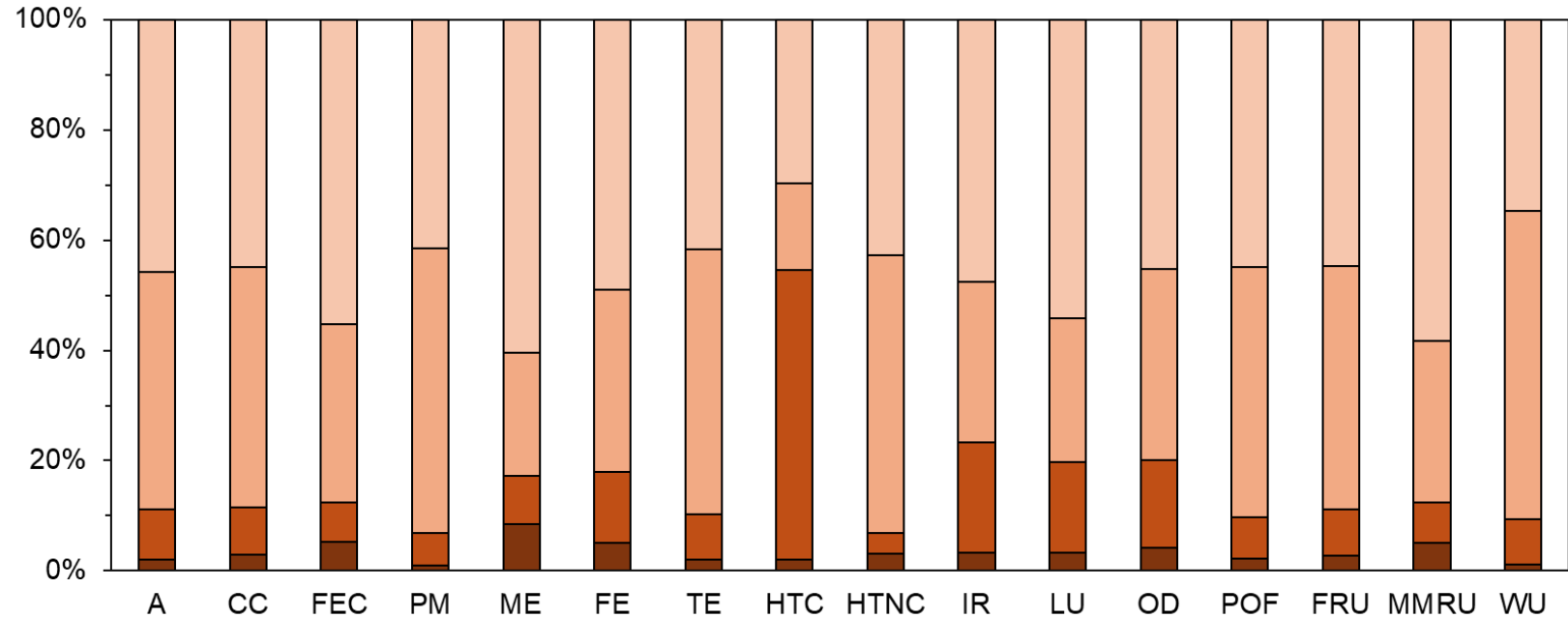

Impact categories: Acidification (A); Climate change (CC); Freshwater ecotoxicity (FEC); Particulate matter (PM); Marine eutrophication (ME); Freshwater eutrophication (FE); Terrestrial eutrophication (TE); Human toxicity cancer (HTC); Human toxicity non-cancer (HTNC); Ionizing radiation (IR); Land use (LU); Ozone depletion (OD); Photochemical ozone formation (POF); Fossil resource use (FRU); Minerals and metals resource use (MMRU); Water use (WU).

3 | Life cycle assessment

Impact analysis – NADES approach

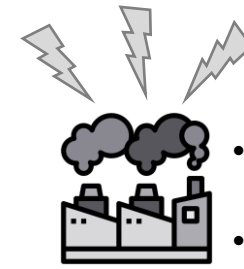

• Citric acid

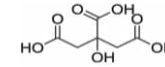

• Xylitol

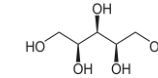

Subsystems:

■ SS1-Feedstock processing

■ SS3-Extraction

■ SS4-Purification

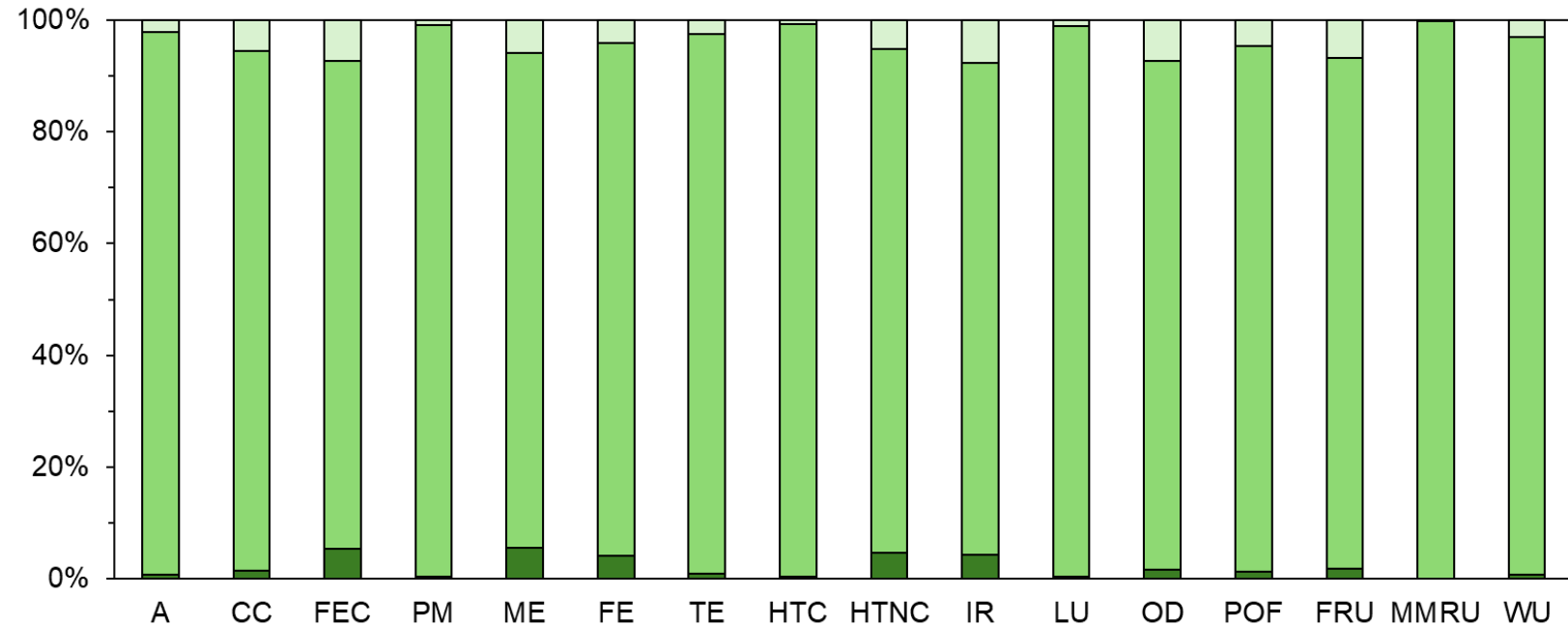

Impact categories: Acidification (A); Climate change (CC); Freshwater ecotoxicity (FEC); Particulate matter (PM); Marine eutrophication (ME); Freshwater eutrophication (FE); Terrestrial eutrophication (TE); Human toxicity cancer (HTC); Human toxicity non-cancer (HTNC); Ionizing radiation (IR); Land use (LU); Ozone depletion (OD); Photochemical ozone formation (POF); Fossil resource use (FRU); Minerals and metals resource use (MMRU); Water use (WU).

3 | Life cycle assessment

Impact analysis – Final remarks

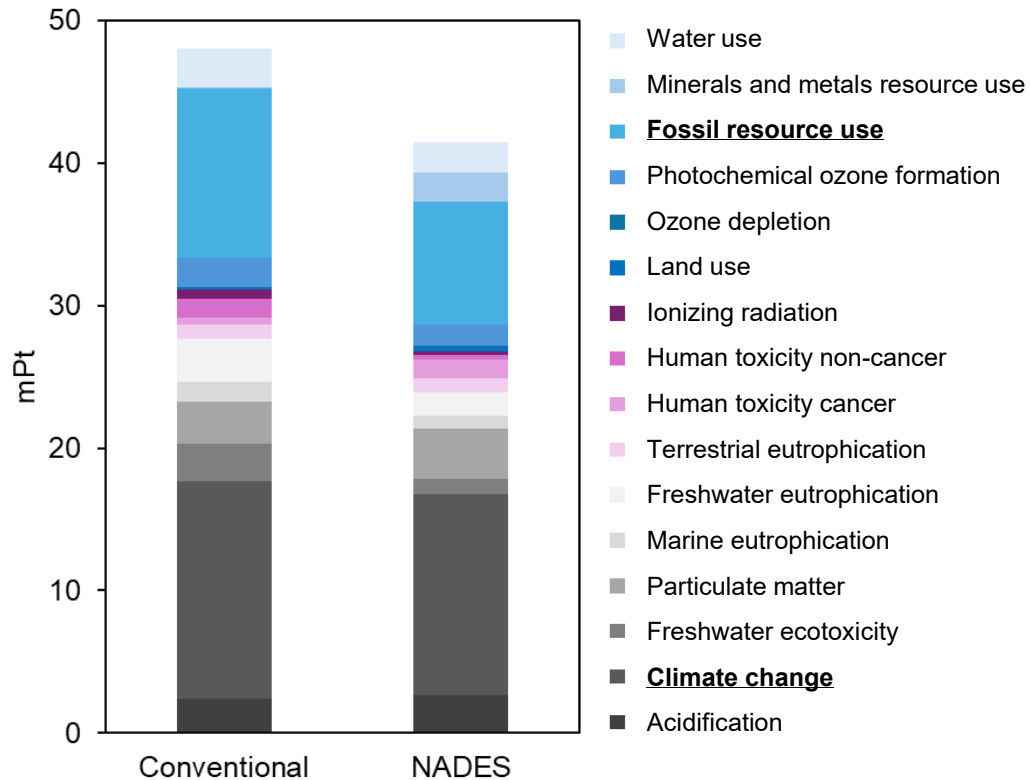

Novel collagen extraction method revealed a **14% decrease** in the total environmental impact compared to the conventional approach.

The statement in the previous work, "more sustainable when compared with the conventionally used extraction", should be cautiously made.

This study underscores the value of systematic LCA assessments and the role of LCA as a **powerful decision-support tool** for enhancing process sustainability.

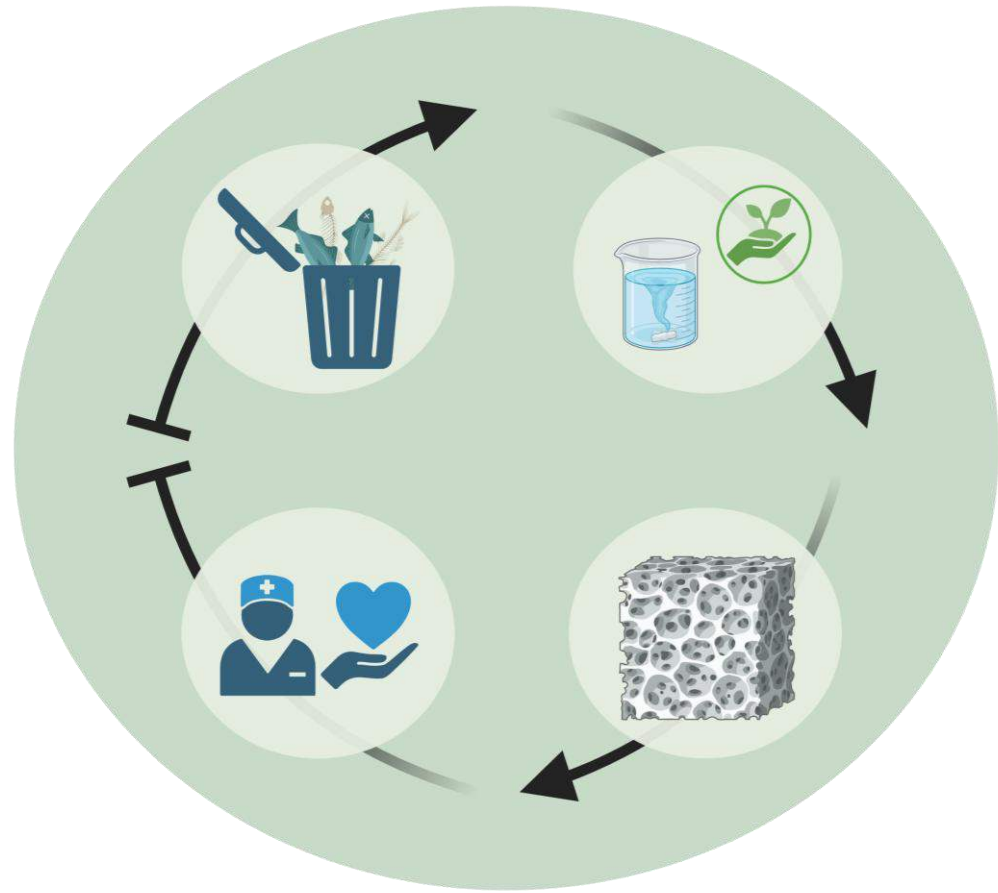

4 | Final remarks

4 | Final remarks

- Successful alternative NADES methodology for pure type I collagen extraction
- LCA suggested a decreased environmental impact of the traditional method

Prospects

- Environmental impact improvement of the NADES approach and the economic sustainability
- NADES process performance at pilot or industrial scales

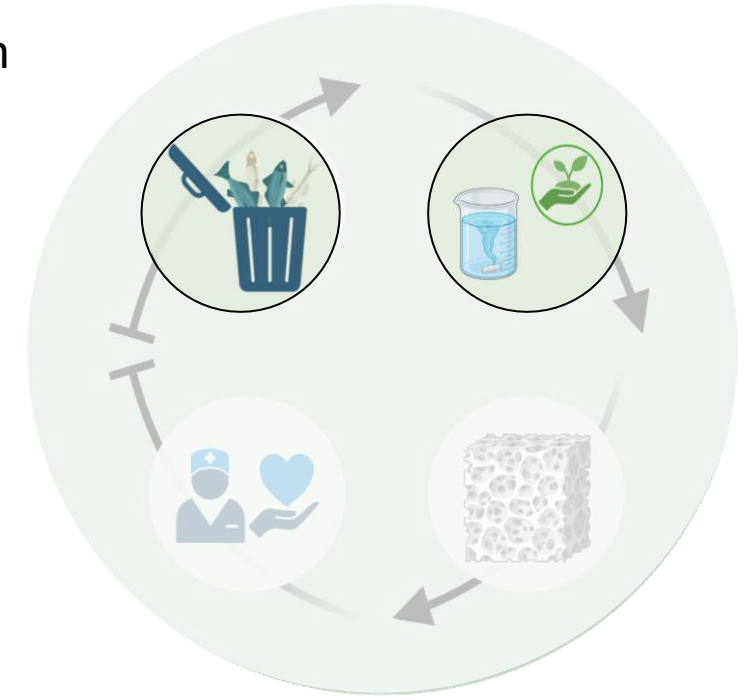

Acknowledgements



Prof. Maria do Rosário Bronze, PhD



Prof. Ana Rita Duarte, PhD



Frédéric Gaspar, PhD



PhD fellowship:
2021.06269.BD



iNOVA4Health
-Advancing Precision Medicine-



VITORINO & FILHOS, LDA.

FITEC
Fundo de Inovação, Tecnologia
e Economia Circular



Prof. Pavel Gurikov, PhD



Baldur Schroeter, PhD



Tiago Lopes, PhD

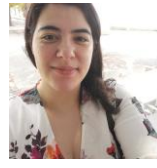

Joana Ortigueira, PhD



Prof. Joana Marto, PhD
Dermo lab colleagues



Natural Bioactives and Nutraceuticals lab colleagues



Microbiology for Sustainability lab colleagues



Des.Solve lab colleagues



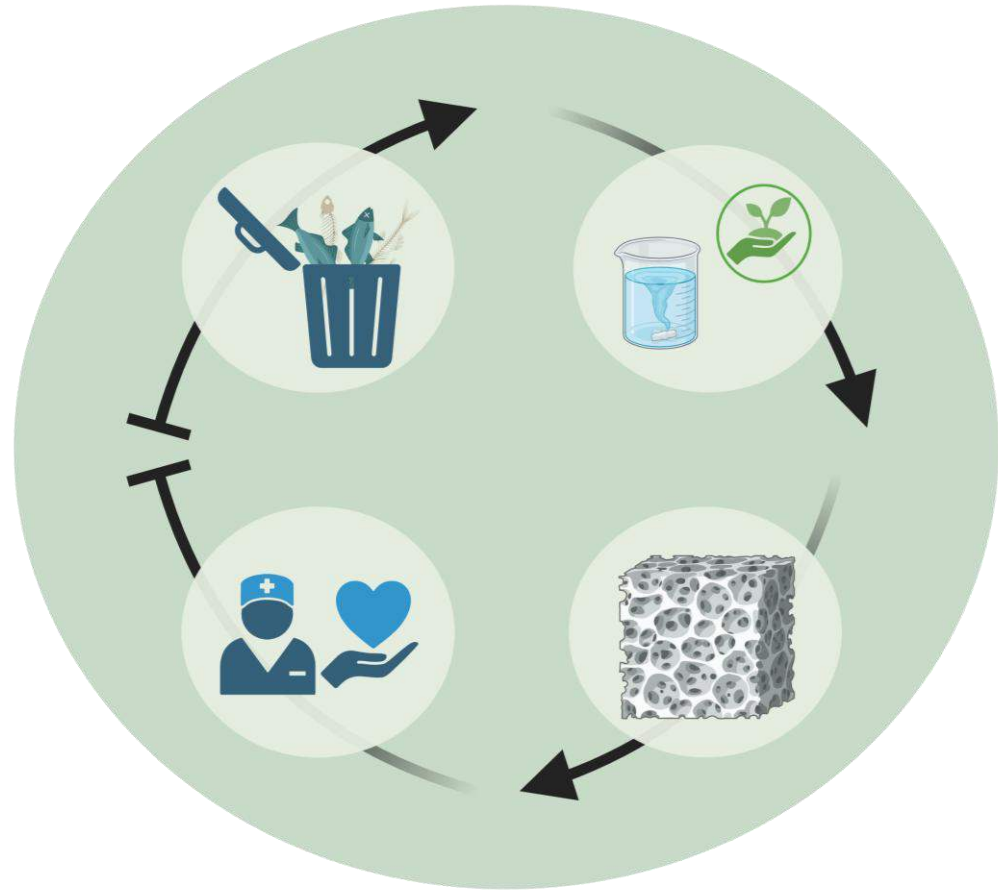

Thank you